

## APPLICATIONS

- Self-service island hot food bar
- Medium temperature (140°-165°)
- Available with either wet or dry wells (wet achieves better performance)

## STANDARD FEATURES

### CABINET CONSTRUCTION

- Base - 3/4" plywood construction finished in high pressure plastic laminate
- Countertop to be high pressure laminate.
- Storage area has houses electrical and plumbing components.
- 2 rows of protective 1" vinyl bumpers.
- 6" high stainless steel adjustable legs (unit must be leveled plumb at time of installation).

### STANDARD FEATURES

- Base Cabinet and Counter top covered with high pressure black laminate
- Soup wells include insets, lids, & ladles
- Cup dispensers and accessorie Pans
- Drains connected through a manifold to a single drain valve.
- Infinite (dial) control with pilot light.

### CANOPY/SNEEZE GUARD

- Square stainless steel support tubing
- 14 gauge stainless steel top
- Tempered fixed glass sneeze guard
- LED lights

### HEATED FOOD MERCHANDISING

- NSF-4 soup wells warm uniformly keeping product at optimum temperature.
- Drains connected through a manifold to a single drain valve.
- Infinite (dial) control with pilot light.

### ELECTRICAL REQUIREMENTS

- Unit is pre-wired and furnished with a Junction box for use on a dedicated 120/208V, 60Hz, 1 phase circuit.

### WARRANTY

- One year - Parts and Labor

60" Half-Round Unit with optional finishes.

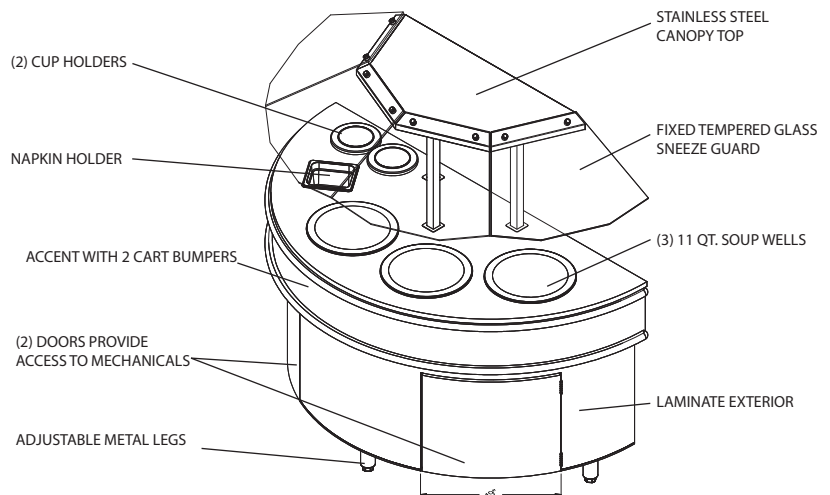

Engineered for stores with ambient conditions not to exceed 75°F and 55% relative humidity. Due to continuous improvements specifications may change without notice.

## OPTIONS / ACCESSORIES

- Fixture is customizable and can accommodate limitless configurations
- Countertop available in many colors of laminate, solid surface or quartz engineered stone as well as stainless steel.
- Many laminate colors available for exterior laminate, vinyl bumper, and powder coat
- Canopy without tempered glass (check local sanitation laws before ordering without canopy)
- Counter top configurations available to include tray slides, utensil holders, small pans and dispensers for plates, cups/bowls, lids and napkins.
- Metal or mirrored laminate accent strip

Built to meet the following specifications:



*Line drawings depict a 60" Half-Round Unit*

Unit Length	Number 11 QT Wells	Dimensions (inches)		
		L	D	H
40"	2	40	30	56
60"	3	60	30	56

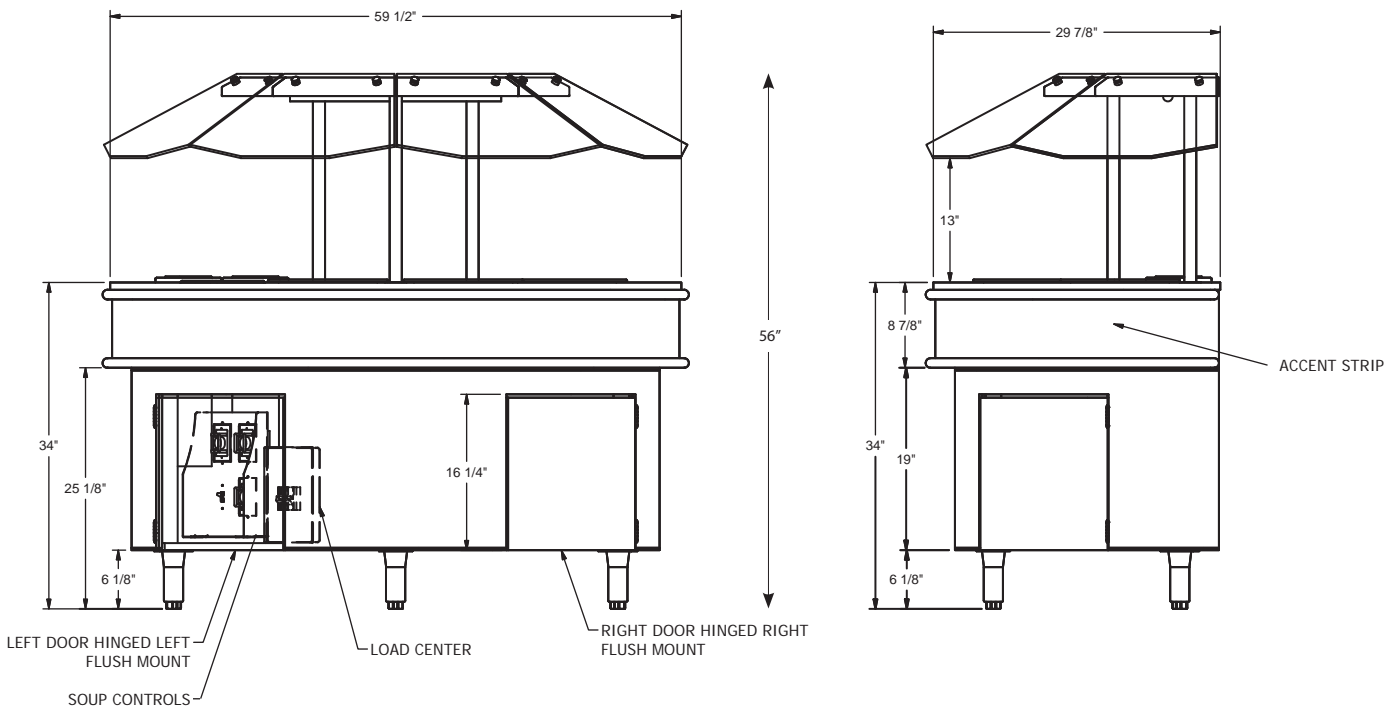
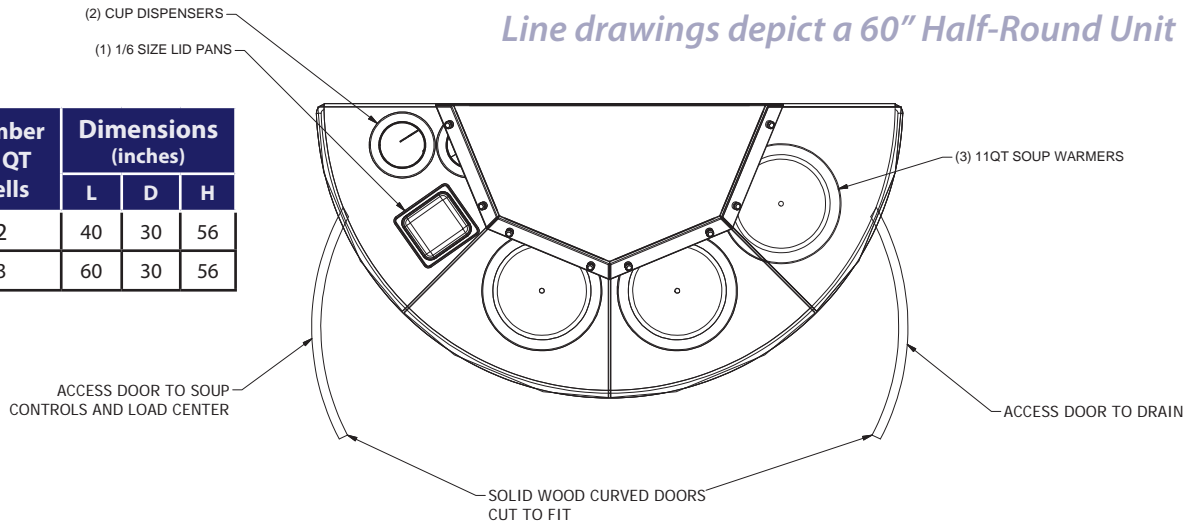

## ELECTRICAL SPECIFICATIONS BASED ON 60" UNIT

ELECTRICAL REQUIREMENTS - (WIRED TO LOAD CENTER)							
QTY	DESCRIPTION	MANUFACTURER	MODEL #	VOLTAGE	L-1 AMPS	L-2 AMPS	BREAKER RATING
1	SOUP WELL	HATCO	HWB-11QT	120	6.7		15A SINGLE
2	SOUP WELL	HATCO	HWB-11QT	120		13.4	15A PIGGY BACK
1	2' LED LIGHTS	ELECTRALED	EFDS	120		.25	
TOTAL AMPS PER LINE						13.4	13.65
TOTAL ELECTRICAL REQUIRED IS 120V/208V, 60 Hz, 1 PH						13.65	AMP LOAD, 4 WIRES