

APPLICATIONS

- Self-Service dry donut/pastry case with sectioned, individual flip up doors
- Rear sliding doors for easy tray loading

STANDARD FEATURES

CABINET CONSTRUCTION

- Unit built with steel frame and finished in high pressure laminated exterior panels.
- Removable Solid End Panels allow multiple units to be connected in an endless series.
- 1/4" thick tempered double bent curved glass with lift handle.
- Rear access clear sliding doors.
- Top to be 18 gauge stainless steel.
- 2 rows of protective 1" vinyl bumpers.

SHELVING

- Adjustable 1/4" thick tempered glass shelves and 18 gauge steel deck pans are easily removable.
- 3 standard shelves on all models + deck
- Full height shelf support pilasters with slotted holes on 1" centers for vertical shelf adjustments.
- Brackets allow shelf to be adjusted to 3 different angles to increase visibility.
- LED lights illuminate shelf area below

ELECTRICAL REQUIREMENTS

- Pre-wired and furnished with a junction box for use on a dedicated 120V, 60Hz, 1 phase circuit.

WARRANTY

- One year - Parts and Labor

OPTIONS / ACCESSORIES

- Powder coated interior and top.
- Mirrored Interior End Panels
- Assorted colors available for laminate, vinyl bumper and powder coat.
- Extra shelves
- Wire or sheet metal shelves
- Rear access mirrored sliding doors
- Front accent lighting
- Cord set instead of junction box

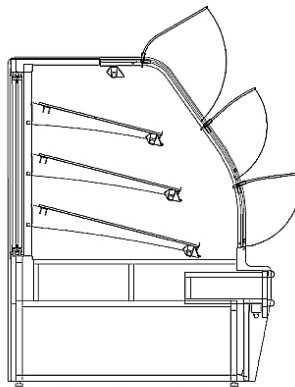

Shown with accent light.

The Euro Donut Case features flip up curved acrylic doors that keep product fresh and accessible at the same time.

Rear sliding doors ease product loading

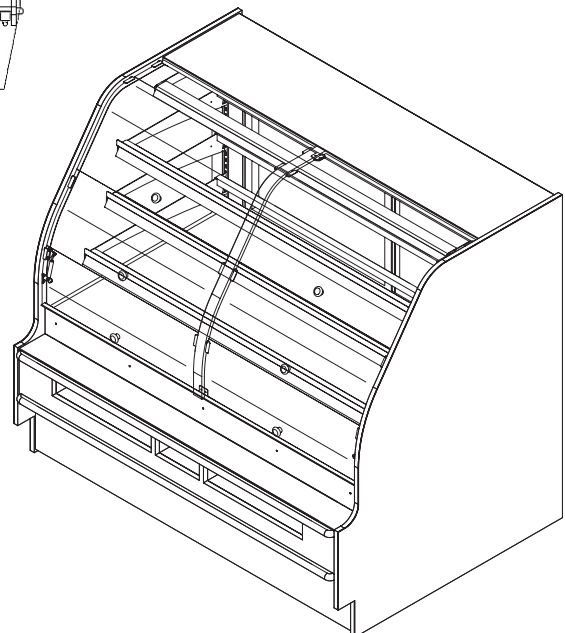

Engineered for stores with ambient conditions not to exceed 75°F and 55% relative humidity. Due to continuous improvements specifications may change without notice.

Built to meet the following specifications:



LINE DRAWINGS BASED ON A 6' MODEL

Front View

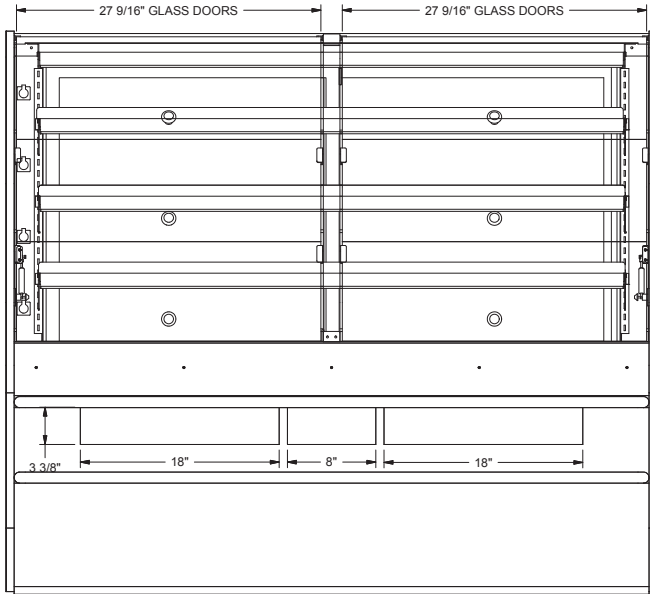

Side View

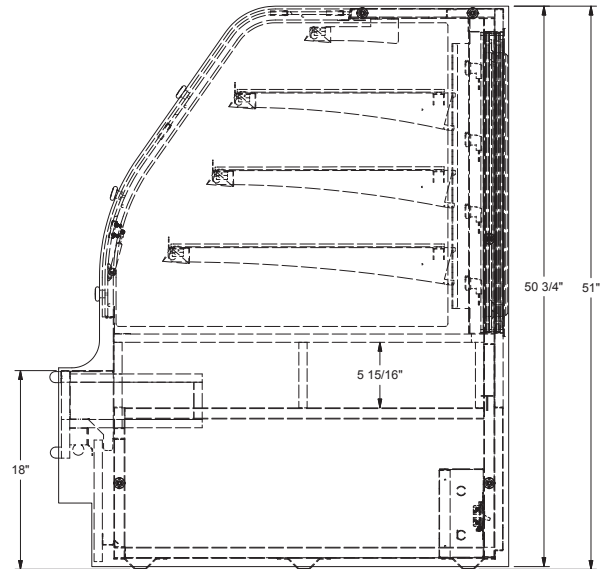

Top View

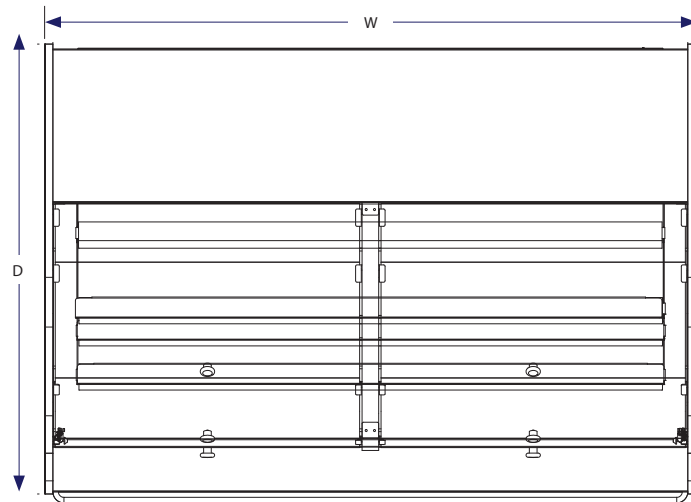

Unit Width	Dimensions (inches)		
	W	D	H
48"	48 1/2	41 1/2	51 1/2
59"	59 1/2	41 1/2	51 1/2
77"	77 1/2	41 1/2	51 1/2

ELECTRICAL/REFRIGERATION SPECIFICATIONS - (BASED ON A 48" UNIT)

ELECTRICAL REQUIREMENTS - ON 6' CORD NEMA 15-15P PLUG						
QTY	DESCRIPTION	MANUFACTURER	MODEL #	VOLTAGE	AMPS EA	AMPS TOTAL
4	LIGHTS	ELECTRALED	EFDS-3-3500	120	0.17	.68
TOTAL ELECTRICAL REQUIRED IS 120/208 V, 60 Hz, 1 PH						.68